

Automatic Recirculation Valves

for
Centrifugal Pump
Minimum Flow
Protection

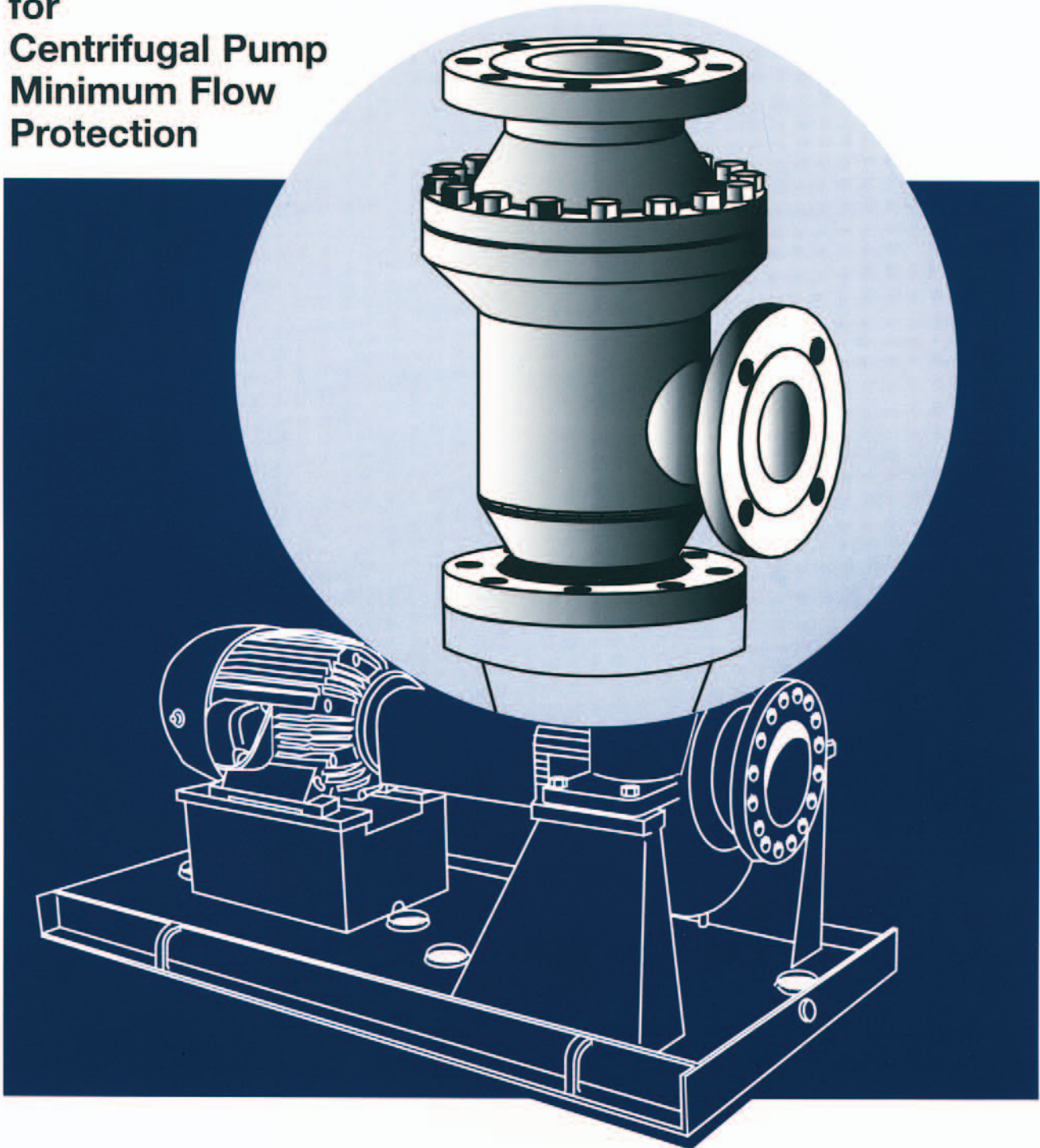

HBE

ENGINEERING Inc.

205 Portage Avenue, Three Rivers, MI 49093 U.S.A.
Phone: 269-279-2035 Fax: 269-278-6745

The DLPM series automatic recirculation valve was developed for centrifugal pump protection, providing the following features and benefits.

OPERATIONAL DEPENDABILITY

The valve has only one moving part. No pilot valves or linkages are required for operation. The combination check valve/flow sensing element is guided at the top and bottom for smooth operation.

MULTI-FUNCTION VALVE

Provides economical and reliable protection against low flow and reverse flow conditions. The valve combines the functions of 1) main line check valve, 2) flow sensing element, 3) bypass flow control, 4) bypass pressure reduction. The DLPM eliminates at least seven separate components used in a conventional system.

SELF POWERED

The valve operates without air or electric power and is easily installed with three connections.

OPERATIONAL OVERVIEW

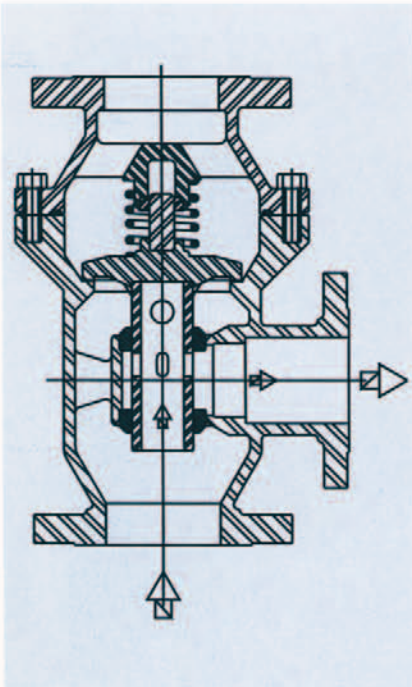

No main flow demand, minimum flow through bypass

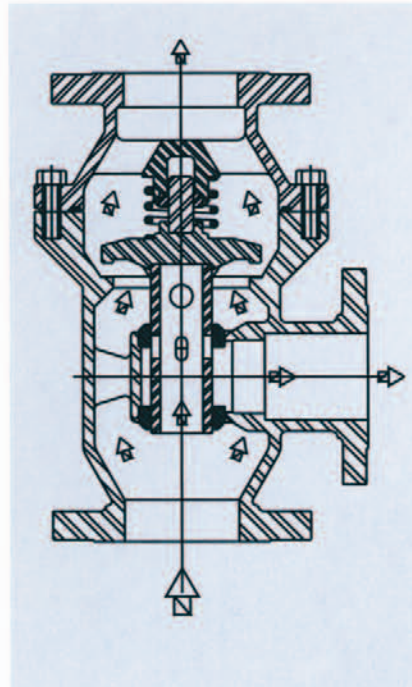

Modulating flow, main flow is less than minimum flow

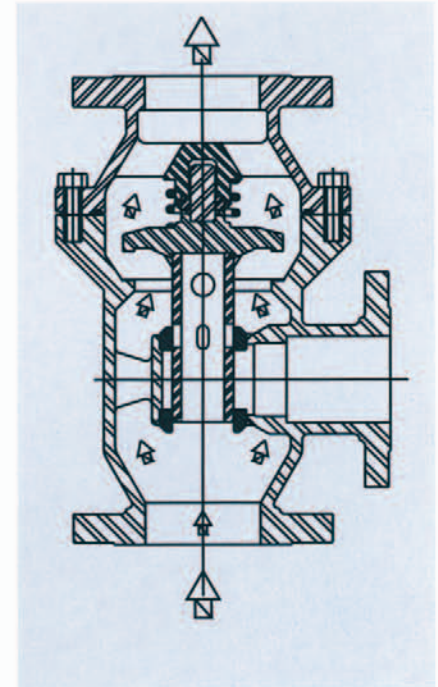

Main flow greater than minimum flow, bypass closed

INDUSTRIES:

The valve was developed to serve pump protection requirements of the following; Power, Refining, Chemical, Petro-chemical, Pharmaceutical, and HVAC.

INSTALLATIONS:

Typical installations include: Transfer, Feeding, Circulating, Boosting, and Loading Pumps.

USAGE:

Typical uses include centrifugal pumps of ANSI/API configuration, vertical turbine, and canned motor design.

APPLICATIONS:

In general any clean liquid which passes through a strainer or filter before entering the valve. Typical services include but are not limited to boiler feed water, raw water, condensate, gasoline, diesel fuel, light hydrocarbons, and feed stocks.

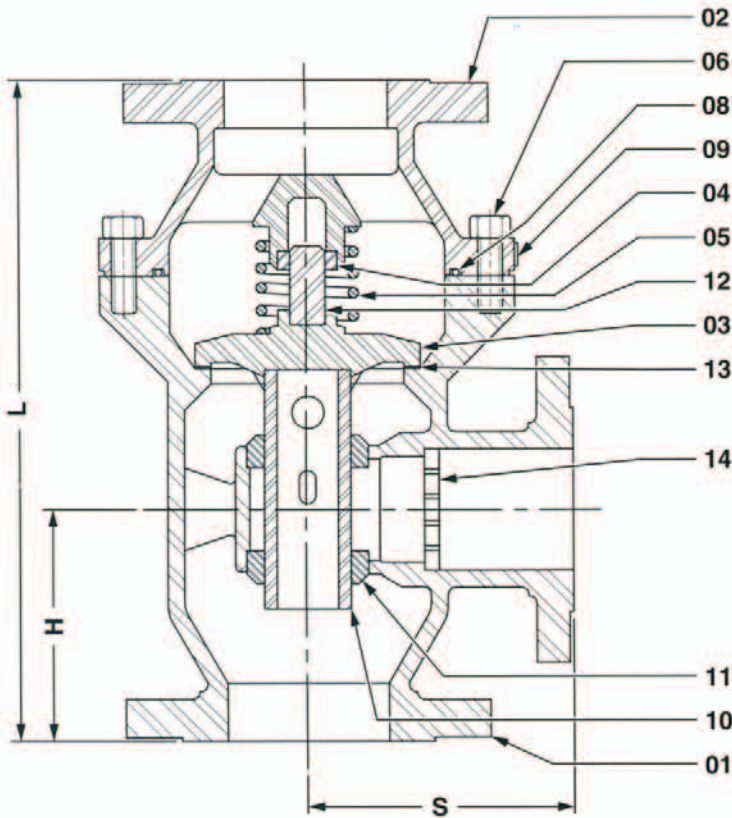

Normal Sizes Inch		Pressure Class LBS	Dimensions Inch			Weights Lbs
Main	Bypass		L	H	S	
1	0.75	150	9.6	3.4	4.3	22
		300	9.6	3.4	4.3	33
		600	9.6	3.4	4.5	46
1.5	0.75	150	9.6	3.4	4.3	26
		300	9.6	3.4	4.3	37
		600	9.6	3.7	4.5	48
2	1	150	10.9	4.0	4.9	40
		300	10.9	4.0	4.9	48
		600	11.6	4.3	5.1	57
3	2	150	14.1	4.6	5.6	66
		300	15.5	5.1	6.0	92
		600	16.3	5.3	6.8	119
4	3	150	15.8	5.4	6.8	108
		300	18.2	6.2	7.3	158
		600	19.6	6.6	8.1	220
6	4	150	21.0	6.9	8.4	220
		300	22.8	7.5	9.3	315
		600	25.0	8.1	10.4	453
8	6	150	29.5	9.6	10.8	438
		300	31.3	10.2	11.6	598
		600	33.7	10.8	12.6	779
10	8	150	35.4	11.8	13.4	946
		300	37.4	12.6	14.2	1342
		600	43.3	14.4	16.3	1925

Consult HBE for Larger Size Requirements.

Item	Description	Materials	
1	Body	Carbon Steel	ASTM A216 WCB
2	Bonnet	Carbon Steel	ASTM A216 WCB
3	Disc	Stainless Steel 304	ASTM A276
4	Slide Ring	Stainless Steel 17-4PH	ASTM A747 17-4 PH
5	Spring	Stainless Steel	AISI 302
6	Stud Bolt	Carbon Steel	ASTM A193 B7
8	O-Ring	EPR (Others Available)	—
9	Name Plate	Stainless Steel 304	ASTM A276
10	Piston	Stainless Steel 304	ASTM A276
11	Bypass Ring	Stainless Steel 17-4 PH	ASTM A747 17 4PH
12	Disc Guide	Stainless Steel 304	ASTM A276
13	Seat	Stainless Settl Deposit	AWS E309
14	Orifice	Stainless Steel 304	ASTM A276

Normal Sizes Inch		Flows GPM		Bypass Cv	
Main	Bypass	Main Max	Bypass Max	Max	Min
1	0.75	60	35	6.1	0.5
1.5	0.75	125	35	6.1	0.5
2	1	250	75	8.5	1.0
3	2	500	165	17.0	2.0
4	3	900	320	36.4	3.0
6	4	2000	650	91.0	5.0
8	6	3300	1250	169.8	7.0
10	8	5500	2400	425	25.0

VALVE MODEL LEGEND

DLPM – Low pressure modulating automatic recirculation valve. 150 lb. and 300 lb. ANSI Class.

DMPM – Medium pressure modulating automatic recirculation valve. 600 lb. ANSI Class

BACK PRESSURE ACCESSORIES

Depending upon the bypass pressure differential, an orifice can be installed inside the bypass as illustrated above. In addition, a remote orifice or BPR (back pressure regulator) which is installed in the bypass piping may be required. HBE will quote and supply the necessary orifice or BPR with illustrative drawings and installation instructions to assure the valve operates quietly without two phase flow during bypass operation.

SIZE CODE	PRESSURE CLASS CODE	QUOTE/ORDER FILE NUMBER
04 = 1"	015 = 150	(xxxx)
06 = 1-1/2"	030 = 300	
08 = 2"	060 = 600	
12 = 3"		
16 = 4"		
24 = 6"		
32 = 8"		
40 = 10"		

EXAMPLE
 3" – 300 Lb. flanged valve
 File 4124
 Model DLPM-12-030-4124
 A written description of the material of construction details follows the model number.

How To Order and Specify

The centrifugal pump shall be protected by the DLPM series automatic recirculation valve which is completely self-contained and fully automatic via flow activation.

The valve protects the pump from reverse flow and prevents overheating during low process demands.

Operation of the valve bypass will be modulating so the sum of the main and bypass flow will never be less than the minimum flow requirement of the pump.

Valve design will incorporate a radial split body, spring assisted check valve disc and inline bypass. Materials of construction will consist of a cast carbon steel body ASTM A216 grade WCB with stainless steel internals. If service conditions dictate other materials are available such as stainless steel, low temperature steel and nickel alloys.

The valve will be designed to operate without flashing or cavitation occurring during bypass operation. Any necessary accessories such as orifices or back pressure regulators will be provided by HBE to prevent flashing or cavitation in the bypass piping.

Required Application Data

Main Flow

Minimum _____ GPM (m³/hr)
Maximum _____ GPM (m³/hr)
Normal _____ GPM (m³/hr)

Minimum Pump Flow _____ GPM (m³/hr)

Pump Discharge Pressure @:

Normal Flow _____ PSIG (kpa)
Bypass Flow _____ PSIG (kpa)
Shut off _____ PSIG (kpa)

Bypass Backpressure _____ PSIG (kpa)

Temperature

Normal _____ °F (°C)
Maximum _____ °F (°C)

Liquid

*Specific Gravity _____
*Vapor Pressure _____ psia
*Viscosity _____ centipoise
(*if other than water)



ENGINEERING Inc.

205 Portage Avenue
Three Rivers, MI 49093 U.S.A.
www.hbe-engineering.com

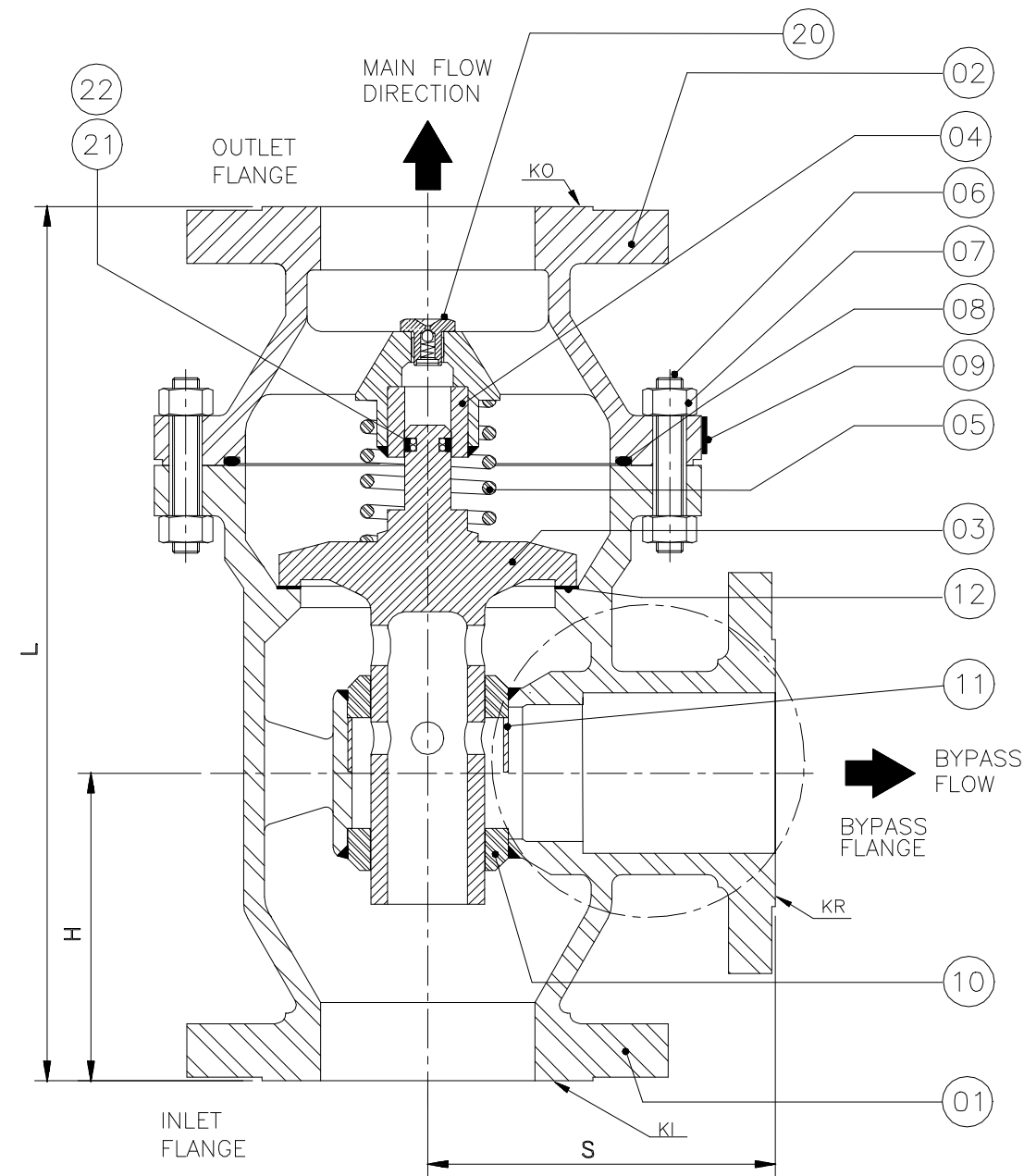

ITEM	QTY.	DESCRIPTION	MATERIALS	SPECIFICATION
1	01	BODY	SEE NOTE -2	-----
2	01	BONNET	SEE NOTE -2	-----
3	01	DISC OBT.	ST. ST.	CF8
4	01	SLIDE RING	ST. ST.	17-4PH
5	01	SPRING	ST. ST.	AISI 302
6	(3)	STUD BOLT	CARBON STEEL	ASTM A 193 B7
7	(3)	NUT	CARBON STEEL	ASTM A 194 2H
8	01	" O " RING	SEE NOTE -10	-----
9	01	NAME PLATE	ST. ST.	AISI 304
10	01	BY-PASS RING	ST. ST.	17-4PH
11	01	LOWER SLIDE RING	ST. ST.	17-4PH
12	01	SEAT	ST. ST. DEPOSIT.	AWS E 316 L
19	01	ORIFICE	ST. ST.	AISI 304
20	01	DAMPENING VALVE	ST. ST.	-----
21	02	PRESSURE RING	SEE NOTE -10	-----
22	01	SLIDE RING	TEFLON	AISI 304

NOTES:

- 1- RECOMMENDED SPARE PARTS.
- 2- BODY AND BONNET MATERIALS
 - CARBON STEEL - ASTM A 216 WCB
 - STAINLESS STEEL - ASTM A 351 CF8M
- 3- QUANTITY DEPENDS ON VALVE SIZE
- 4- ACCESSORY:
 - BPR VALVE
 - ORIFICE, IN BYPASS LINE
 - ORIFICE, ITEM 19
 - NONE
- 5- DIMENSIONS: L= _____ H= _____ S= _____ inch mm
- 6- FLANGE CONNECTIONS IN ACCORDANCE WITH ANSI B 16.5 - _____ # DIN _____
- 7- SIZE: KI & KO = _____ KR = _____
- 8- WEIGHT : _____ Lbs Kg
- 9- TRIM _____, MAIN _____, REC _____, Cv Kv
- 10- EPR VITON TEFLON BUNA-N _____
- 11- INSTALLATION : VERTICAL HORIZONTAL
- 12- TOLERANCES ± 1/16" (1.6mm)

CUSTOMER: _____

PURCHASE ORDER #: _____

HBE REFERENCE #: _____

DATE: _____

MODEL: _____

TAG #: _____

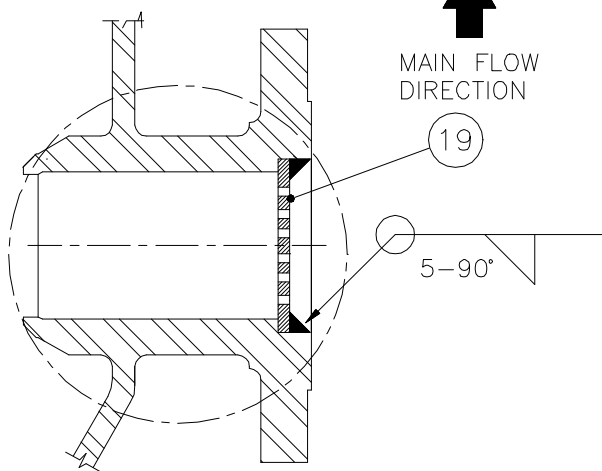

ACCESSORY ORIFICE SEE NOTE 4

		AUTO RECIRCULATION VALVE		SIZE 3" TO 14"	
		MAT. SEE TABLE		HEAT TREAT. * * * * *	
		DRAW BY		CHECKED BY	
		APPROVED BY		DATE	
		SCALE		NONE	
LETTER	DONE DATE	APPROVED	REVISION	SHEET	DWG REF.
				1 OF 1	DWG #:
HBE ENGINEERING INC.					