

**CENTURY**

# **Diaphragm**

**Valves & Actuators**



**Century Instrument Co.**

**Bulletin DV-13**

# CENTURY Diaphragm Valves

Century's broad line of diaphragm valves are widely applied throughout the chemical, food, paper, steel, mining, power, pharmaceutical, and other process industries wherever positive shut-off, non-contamination, or ease of maintenance is required. Available with a wide range of manual and automatic actuators, these valves are available with **weir** and **straightway** flow patterns, as well as in a **sanitary** design. Sizes range from 1/4" thru 3" threaded or weld ends; and 1/2" thru 16" flanged ends. Pressure ratings to 200 psi and temperatures to 340° F.

## Choose the Economical and Versatile Weir Design for General Use or the Tough Corrosive and Abrasive Services

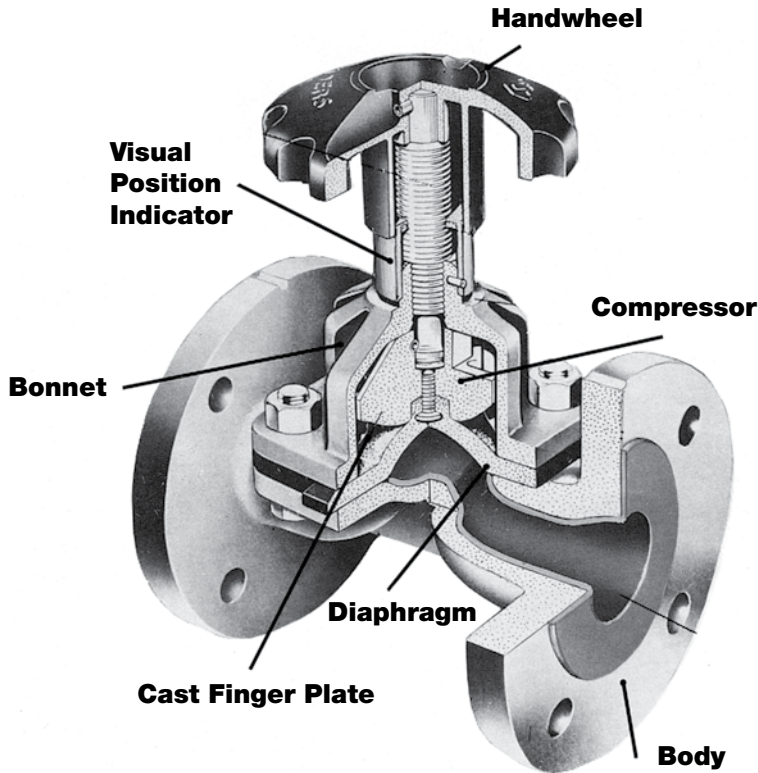

### Century Diaphragm Valves Feature:

- Leaktight performance
- Complete isolation between the bonnet works and process fluid
- Packless stem
- Extremely simple maintenance
- Assured quality
- Unbroken flow
- Closure limiter
- Manual or automatic operators
- Low pressure loss
- Rugged design
- Position indicator

### Dimensions

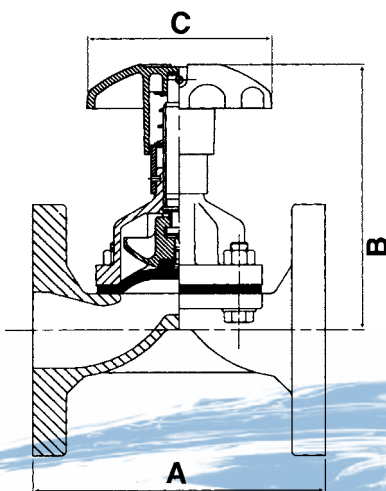

SIZE (Inches)	A					B	C	HAND WHEEL
	THREADED	FLANGED						
		UNLINED	RUBER	GLASS	PLASTIC			
1/4	1-3/4	—	—	—	—	2-1/8	2-3/8	1-1/2
3/8	1-3/4	—	—	—	—	2-1/2	2-3/4	1-7/8
1/2	2-1/2	4	4-1/4	4-1/8	3-3/4	3	3-3/4	2-1/4
3/4	3-1/4	4-5/8	4-7/8	4-3/4	5-3/4	3-1/8	4-1/2	2-3/4
1	4-1/4	5	5-1/4	5-1/8	5-3/4	3-7/8	4-7/8	3-1/4
1-1/4	4-7/8	5-3/4	6	5-7/8	6-1/4	4-1/2	5-3/4	3-3/4
1-1/2	5-3/4	6-1/4	6-1/2	6-3/8	6-3/4	5-1/4	6-1/4	4-5/8
2	6-1/2	7-1/2	7-3/4	7-5/8	7-3/4	5-7/8	7	5-1/2
2-1/2	8-1/2	8-1/2	8-3/4	8-5/8	8-3/4	7-1/8	8-5/8	6-1/2
3	10-1/8	10	10-1/4	10-1/8	10-1/4	7-3/8	9-1/2	7-3/4
4	—	12-1/2	12-3/4	12-5/8	12-3/4	9-1/8	11-3/4	12-1/4
5	—	14	14-3/8	14-1/8	—	11-1/8	14-1/4	12-1/4
6	—	16	16-3/8	16/18	16-1/4	13-3/4	16-1/4	14-1/2
8	—	20-1/2	20-7/8	20-5/8	20-3/4	18	23-3/8	19
10	—	25	25-3/8	25-1/8	—	25-3/4	—	23
12	—	29-1/2	29-7/8	29-1/2	—	26-1/8	—	27-1/2
14	—	36-1/4	36-5/8	—	—	26-3/8	—	27-1/2
16	—	36-1/4	36-5/8	—	—	26-3/8	—	27-1/2

# Body Materials and Linings

The following list shows the wide variety of bodies and linings available

Body Material	Lining	Code	Screwed Ends	Flanged Ends
Cast Iron	Unlined	01	1/2" - 3"	1/2" - 10"
Cast Iron	Hard Rubber	02	-	3/4" - 10"
Cast Iron	Soft Rubber	03	-	3/4" - 10"
Cast Iron	Neoprene	04	-	3/4" - 10"
Cast Iron	Butyl	05	-	3/4" - 10"
Cast Iron	Hypalon	06	-	3/4" - 10"
Cast Iron	Glass	07	-	1/2" - 10"
Cast Iron	Saran	10	-	3/4" - 10"
Cast Iron	Polypro.	11	-	3/4" - 8"
Cast Iron	Tefzel	13	-	3/4" - 8"
Cast Iron	Kynar	14	-	3/4" - 8"
Ductile Iron	Unlined	17	1/2" - 3"	1/2" - 8"
Ductile Iron	Hard Rubber	18	-	1" - 8"
Ductile Iron	Soft Rubber	19	-	1" - 8"
Ductile Iron	Neoprene	20	-	1" - 8"
Ductile Iron	Glass	21	-	1/2" - 6"
Ductile Iron	Saran	24	-	3/4" - 8"
Ductile Iron	Polypro.	25	-	3/4" - 8"
Ductile Iron	Tefzel	26	-	3/4" - 8"
Ductile Iron	Kynar	27	-	3/4" - 8"
Ductile Iron	PFA	28	-	3/4" - 8"
Cast Steel	Unlined	40	1/2" - 3"	1/2" - 8"
Cast Steel	Saran	30	-	1" - 8"
Cast Steel	Polypro.	31	-	1" - 8"
Cast Steel	Kynar	32	-	1" - 8"
Cast Steel	Teflon	33	-	1" - 8"
Stainless Steel	Unlined	41	#*1/2" - 3"	1/2" - 8"
Alloy 20	Unlined	42	#*1/2" - 2"	1/2" - 2"
Hastelloy	Unlined	50	#* 1/2" - 2"	-
Saran (solid)	Unlined	43	* 1/2" - 2"	-
Polypro.(solid)	Unlined	44	*1/2" - 2"	-
Kynar(solid)	Unlined	45	*1/2" - 2"	-
PVC(solid)	Unlined	46	*1/2" - 2"	1/2" - 2"
CPVC(solid)	Unlined	49	*1/2" - 2"	1/2" - 2"
Bronze	Unlined	47	1/2" - 2-1/2"	1/2" - 4"
Aluminum	Unlined	48	1/2" - 2"	-

\* Available with socket weld ends.

# Available with butt weld ends through 6"

**Note:** Code number for end connections are: Figd -1, Screwed - 2, Socket - 3, Butt Weld - 4.



## Century Straightway Diaphragm Valves in both Lined and Unlined Designs offer these benefits:

- Full straight through fluid flow
- Excellent for sludges, slurries or viscous fluids
- Flows in either direction
- Isolation of bonnet from fluid
- Easily cleaned with variety of pigs
- Simple in-line maintenance
- Diaphragm over closure limiter
- Consistently leaktight, even with solids in the line

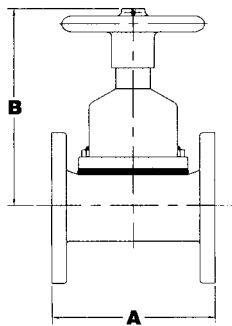
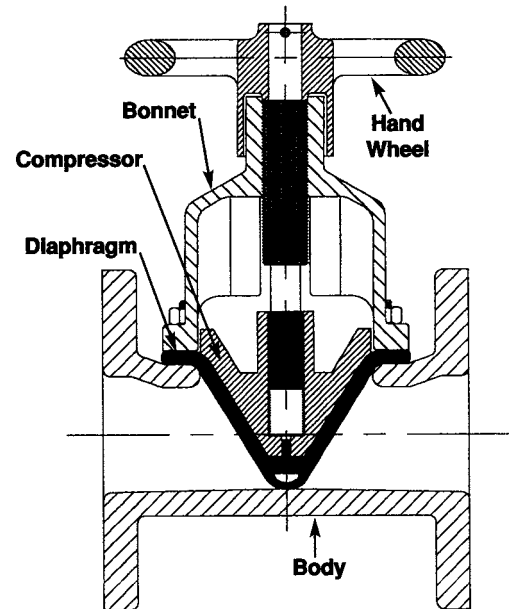

SIZE IN INCHES	1/2	1	1-1/2	2	2-1/2	3	4	6	8	10	12
<b>A UNLINED</b>	4	5-1/2	6-1/2	7-1/2	8-1/2	10	12-1/2	16	20-1/2	25	29-1/2
<b>RUBBER LINED</b>	4-1/4	5-3/4	6-3/4	7-3/4	8-3/4	10-1/4	12-3/4	16-3/8	20-7/8	25-3/8	29-7/8
<b>PLASTIC LINED</b>	4-1/4	5-3/4	6-3/4	7-3/4	8-3/4	10-1/4	12-3/4	16-3/8	20-7/8	25-3/8	29-7/8
<b>GLASS LINED</b>	4-1/8	5-5/8	6-5/8	7-3/8	8-5/8	10-1/8	12-5/8	16-1/8	20-5/8	25-1/8	29-5/8
<b>B</b>	4-1/4	5-3/4	5-3/4	7-1/8	10-1/4	11-5/8	13-7/8	16-5/8	24	33	25
<b>HANDWHEEL</b>	2-1/2	3-1/4	3-1/4	6-1/2	4-3/4	9-1/2	12-7/8	14-1/2	19	23	27-1/2

## Materials and Sizes for Straightway Valves

### Flanged Ends 1/2" through 12"

	Size	1/2	1	1 1/2	2	2 1/2	3	4	6	8	10	12
<b>Flanged-End Valves (Unlined):</b>												
Cast Iron		X	X	X	X	X	X	X	X	X	X	X
Ductile Iron		X	X	X	X	X	X	X	X	X	X	X
<b>Cast Iron Lined with:</b>												
Tefzel (ETFE)			X	X	X	X	X	X	X	X	X	X
Polypropylene			X	X	X	X	X	X	X	X	X	X
Glass	X	X	X	X	X	X	X	X	X	X	X	X
Hard Rubber		X	X	X	X	X	X	X	X	X	X	X
Soft Natural Rubber		X	X	X	X	X	X	X	X	X	X	X
Hypalon		X	X	X	X	X	X	X	X	X	X	X
Butyl		X	X	X	X	X	X	X	X	X	X	X
Neoprene		X	X	X	X	X	X	X	X	X	X	X
EPDM		X	X	X	X	X	X	X	X	X	X	X
<b>Ductile Iron Lined with:</b>												
Tefzel (ETFE)			X	X	X	X	X	X	X	X	X	X
Polypropylene			X	X	X	X	X	X	X	X	X	X
Glass	X	X	X	X	X	X	X	X	X	X	X	X
Hard Rubber		X	X	X	X	X	X	X	X	X	X	X
Soft Natural Rubber		X	X	X	X	X	X	X	X	X	X	X
Hypalon		X	X	X	X	X	X	X	X	X	X	X
Butyl		X	X	X	X	X	X	X	X	X	X	X
Neoprene		X	X	X	X	X	X	X	X	X	X	X
EPDM		X	X	X	X	X	X	X	X	X	X	X

# Automatic Diaphragm Valves

## Standard Actuator Features

Position indicator is standard on all actuators.

### Diaphragm Cases

Rugged high pressure cast iron provided with bosses and pads to facilitate the mounting of accessories such as limit stops, position indicators, limit switches, valve positioners, emergency handwheels, etc.

### Diaphragm Plates

Mild steel to withstand high air pressures without distortion or breakage.

### Internal Seal Assembly

Provides longer stem guide, furnished with two "O" rings thereby preventing side-ways or lateral movement of sliding stem thus ensuring better alignment and closure.

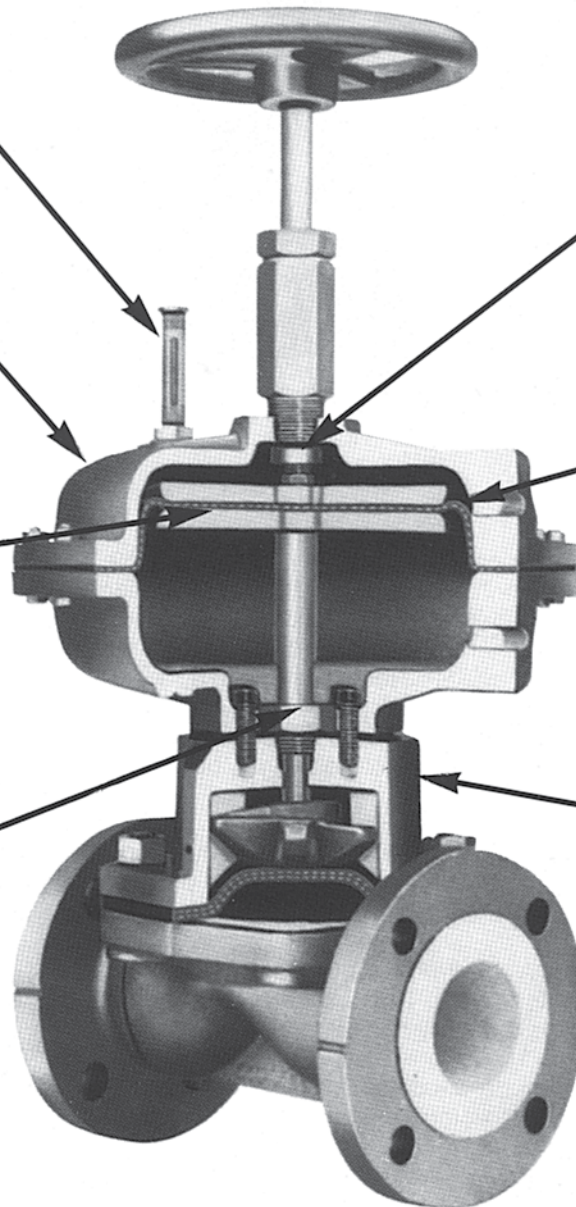

### Captive Handwheel

A positive stop is provided at the "valve open" position. This eliminates any possibility of the wheel and spindle becoming a projectile while being manually "backed off".

### Acuator Diaphragm

Nylon reinforced neoprene molded in a unique way to provide long stroke and long life at air pressures up to 150 psig.

### Acuator Diaphragm

Rugged cast iron, flat top, designed especially for automatic valves, thus eliminating the need for adapter bushing with potentially weak "hour glass" profile.

## Water as Operating Medium

When water instead of compressed air is to be used in the acuator, all cast iron and steel parts are galvanized and all bolts, nuts and screws are stainless steel.

# Automatic Diaphragm Valves

## Features of Series 630 Pneumatic Actuators

---

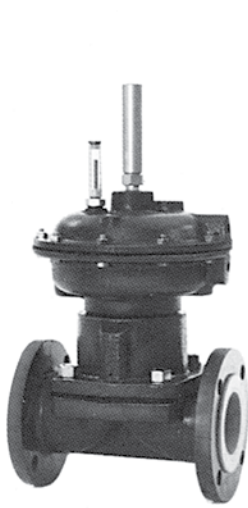

**630-C**

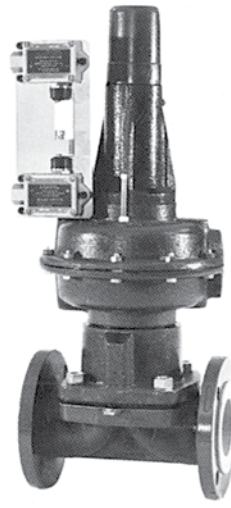

**630-HRT**

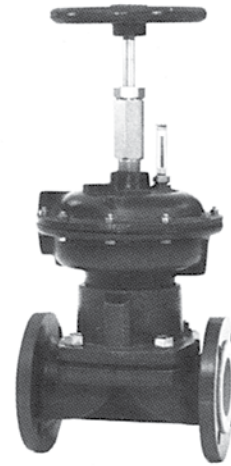

**630-H**

Actuator housing, bonnets and spring cases are made from ASTM 159-70, a high grade pressure type cast iron with 30,000 pounds per square inch tensile strength. Actuator diaphragms are specially reinforced with Nylon and are constructed to offer resistance to ballooning and other forms of deformation. As a result, substantially higher operating air pressures can be used to achieve valve closure than is permissible with competitive actuators of aluminum or pressed steel.

This higher air pressure capability, together with the unusually long stroke of Century pneumatic actuators, makes it possible to use smaller actuators with a significant saving in both cost and space without short stroking the valves.

To facilitate parts inventory and to lower maintenance costs, most components such as actuator diaphragms, seal assemblies, push-rods, etc., are interchangeable between the three modes of actuators, viz., spring open, spring closed and air to air.

To meet and present or future OSHA requirements, the powerful springs in the spring-closed actuator can be fully relaxed prior to dismantling for service. This exclusive feature prevents the spring case housing from becoming a deadly projectile during dismantling for service.

The totally enclosed and epoxy coated non-aluminum construction provides complete protection against the effects of caustic atmospheres and cleaning solutions.

A valve position indicator is included as standard equipment on all Century pneumatic actuators to show the position of the valve in its stroke.

A complete and detailed record is on file at the factory on every valve manufactured during the years since 1950. Keyed to the serial number which appears on the data plate attached to the valve bonnet, this file provides a means of speedily obtaining any information required on every valve we have produced.



# Pneumatic Actuators

These air operators offer a cost-effective solution to a wide range of actuation situations. They are compactly designed to save space and can be mounted in any position. The actuator body is rugged cast iron, with aluminium optional, and when repair is necessary, only a few maintenance parts need to be replaced

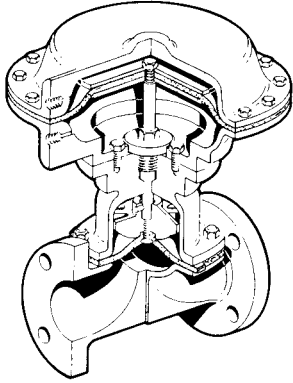

**Air To Open**  
**Air To Close**

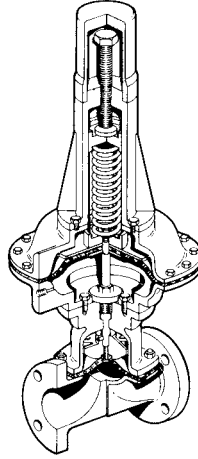

**Spring To Close**  
**Air To Open**

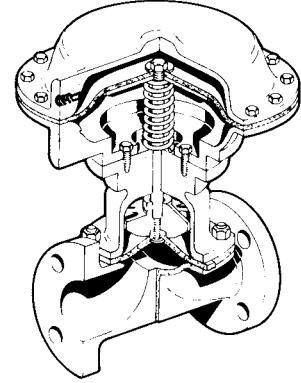

**Spring To Open**  
**Air To Close**

## A Wide Variety of Linings & Diaphragms Mean Valves Tailored to Your Exact Process Requirements

One of the more important features of the CENTURY Diaphragm Valves is the vast combination of materials available in body liner and diaphragms. Most diaphragms are molded in the closed position.

### Linings

- Tefzel (ETFE)
- PFA
- Glass
- Polypropylene
- Hard Rubber
- Soft Rubber
- Butyl
- Neoprene

### Diaphragms

- Teflon (PTFE)
- Viton
- Hypalon
- EPDM
- Neoprene
- Butyl

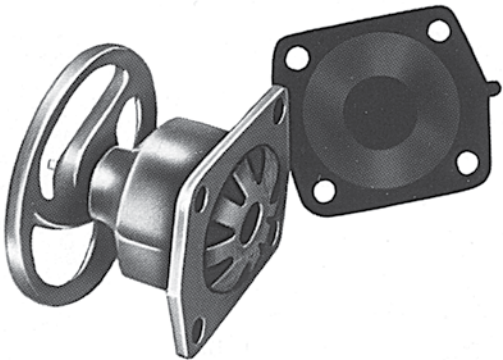

Teflon, Hypalon and Viton are Dupont trademarks.

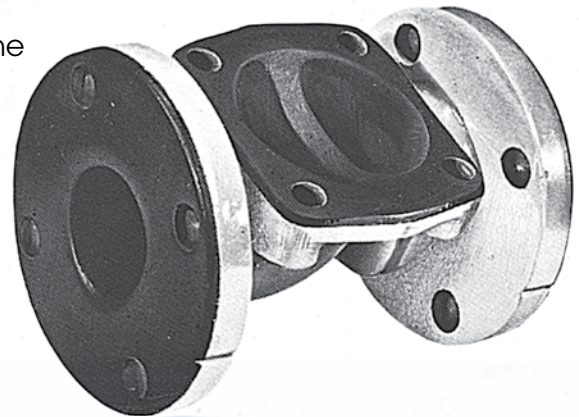

# Manufactures of

---



## Century Instrument Company

11865 Mayfield, Livonia, MI 48150

Phone **734-427-0340** Fax **734-427-5950**

[www.centuryinstrument.com](http://www.centuryinstrument.com)